

The County Collection



Complete Range of Composite Doors



Contents

Composite door features	5
Security	6-7
Glazing options	8-9
Choosing your door	10-11
The Suffolk Range	12-13
The Norfolk Range	14-15
The Essex Range	16-17
The Bedford Range	18-19
The Kent Range	20-21
The Surrey Range	22-23
The Sussex Range	24-25
The Gloucestershire Range	26-27
The Hampshire Range	28-29
The Dorset Range	30-31
The Herefordshire Range	32-33
The Stable Door	34
The Twin Door	35
The Door and a Half	36
Backing glass options	37
Specification	38
Technical data	39



The County Collection, Complete Range of Composite Doors, © Phoenix Door Panels Limited 2011

The Composite Door

First impressions count. Your front door is the first feature people notice about your home; that is why it is so important. Your door makes a statement; it reflects your home's personality, your lifestyle and your aspirations.

This is why we introduced a high-quality, flush-fitting composite door that meets the exacting demands of today's discerning homeowner.

Designed with you in mind, our County Collection is one of the most comprehensive ranges of composite doors on the market.

Choose from seven standard attractive colours, including beautiful woodgrain finishes that look like traditional wooden doors, but don't require the maintenance associated with timber. Or if you prefer, bespoke shades can also be supplied on request.

Today's composite doors are the perfect stylish, secure and low-maintenance choice;

combining superb aesthetics with unrivalled, long-life performance.

With superior weather-tightness, secure locking systems and greater thermal efficiency, your home is fully protected with a modern composite door.

How's that for peace of mind?

Whichever door you select, you can be assured that your door has been made to the highest quality standards. Whether your requirements are for a door with a large glass area to bring light in to your home, or a door with little or no glass to maintain the

privacy in your home, you will find a design to suit in our extensive composite door range.

You and your home deserve the best. Install a County Collection door and you add long-term value, kerb appeal and security to your home – all at the turn of a key.





Why choose a Composite Door – A few things to consider...

Low maintenance – No need to paint or varnish; simply wipe clean.

Security – Technologically-advanced locking systems meet all the requirements demanded from a 21st century entrance door to keep you and your home safe.

Robust - Composite doors are durable, with no twisting, warping or splitting as with timber doors.

Thermally-efficient – Good insulation properties keep out draughts and help to reduce your energy bills.

The Future is Here

Durable and attractive, composite doors are made to last. They are the future for entrance doors.

All County Collection composite doors are manufactured to the highest standards at our dedicated production facilities using top-quality materials.

Our composite doors are produced using robust through-colour GRP door skins. Completely weatherproof, they have excellent resistance to knocks, scratches and whatever the weather throws at them. Unlike other doors, they don't twist, warp or split.

All door designs meet the latest energy efficiency regulations, achieving a U-value of 1.8W/m²K or below. Their thermally-efficient foam cores help to reduce energy bills and keep out noise.

Composite doors are low maintenance with no need to paint or varnish; an occasional wipe over with a

damp cloth will keep your smart new front door looking as good as new.

High security comes as standard, meeting all the requirements demanded from a 21st century entrance door to keep you and your home safe.

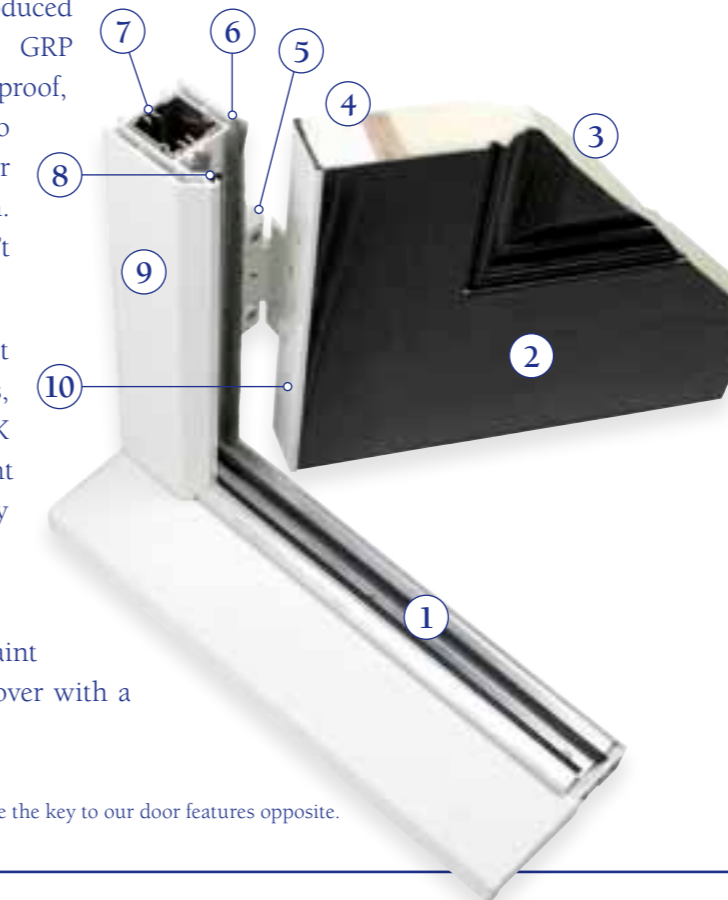

* Please see the key to our door features opposite.

Composite Door Features*

- ① Slimline, low aluminium threshold with twin seals
- ② Strong through-colour GRP facing
- ③ High insulation foam core
- ④ Stable timber inner frame
- ⑤ Adjustable hinges
- ⑥ Wool pile seals x 2
- ⑦ Aluminium reinforced
- ⑧ Q-Lon gasket seal
- ⑨ Dedicated 70mm reinforced PVC-U frame
- ⑩ Grained effect ABS edgeboard



Safe and Secure

Safety and security are uppermost in everyone's mind. 67% of burglars break in through the door, according to Home Office official crime statistics. That's why our County Collection composite doors use only the best quality multi-point locking systems to keep your home and family fully protected.

Secured by Design



Official Police Security Initiative

Feel reassured with a County Collection composite door, which is manufactured in accordance with Secured by Design, a Police-backed accreditation. Secured by Design is the official UK police approval for security products that ensures they are

Our doors are installed within a reinforced door frame and secured with Paddock PL 147 multi-point locks with two hooks, two finger bolts and a deadbolt. Premium hinges and keeps meet the latest standards and legislation.



designed, manufactured and tested within strict rigid guidelines.

County Collection SBD-licensed doors are available as either solid or glazed versions, giving your home the ultimate protection from unwanted intrusion.



No more lost keys! For the ultimate in convenience, why not upgrade to keyless entry? Innovative technology means you can lock and unlock your front door with a handy remote control – just like your car.

We offer the Keyfree electronic lock – the very latest in door security from Yale. Combining peace of mind with convenience, you can access and protect your property without a key.

A small remote control keyfob with a 10-metre range unlocks your home – or enter your own personal code (4 to 12 digits) into the built-in keypad.

Keyfree has been designed and tested to meet Secured by Design and also features a built-in 80-decibel alarm to scare off anyone who tries to attack the lock.

We use high-quality and fully tested locking systems. With these products, you are assured of the best locks that money can buy. (High security PAS 23/24 handles pictured.)



Yale® Keyfree





Clearly Superior Glass

Glass panels not only allow light into your home, they enhance and personalise your door according to your taste. A wide range of hand-crafted exclusive and stylish glazing designs are produced by our specialist team at our in-house glass facilities.

From traditional to contemporary styles, we can supply an eye-catching option that really creates a stunning focal point for your door. We can even supply totally bespoke designs to your own specification, from photographs or drawings for example.



From obscure patterns for privacy to stylish 'sandblasted' designs etched into the glass, you can be sure of finding the one to suit your individual needs and wishes. Intricate leaded styles complement traditional-looking doors or you add a splash of creative colour from our popular Fusion range.

Our double and triple-glazed units are manufactured to BSEN 1279 standards. Both have excellent heat retention properties. Additionally, the elegant triple-glazed units encapsulate the bevel design within the sealed unit for ease of cleaning.



There are countless glazing options for your composite door, including beautiful hand-assembled resin leadwork designs like the one opposite.

A Host of Glazing Options

Just some of the glazing cassette options to choose from.

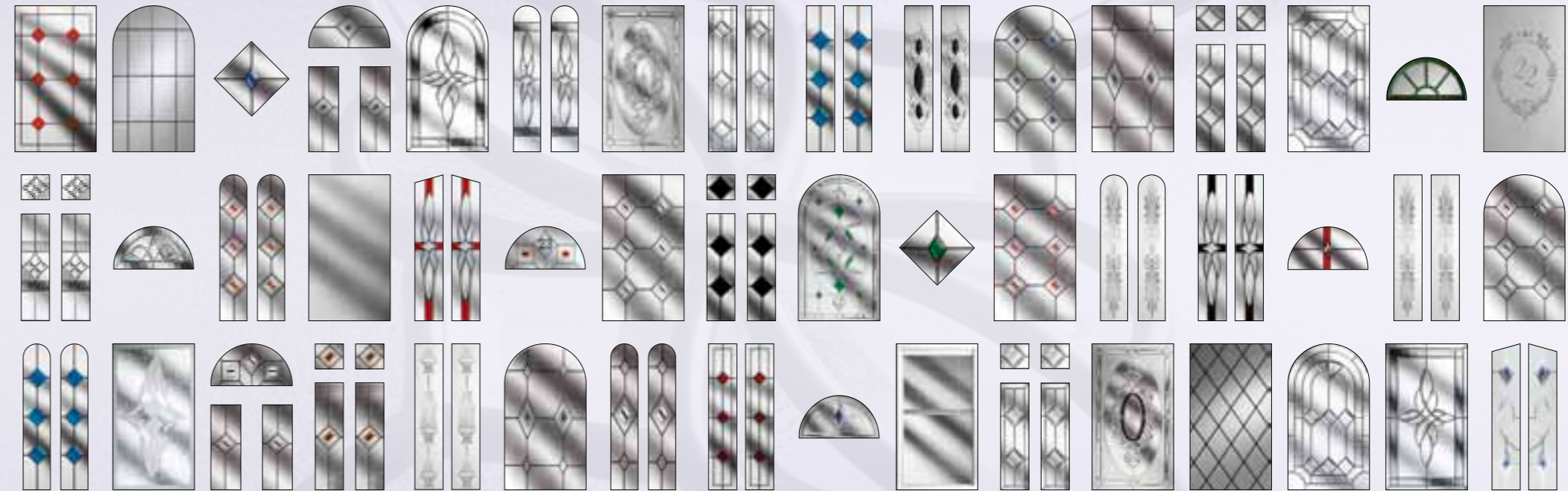

The Composite Door Glazing Cassette Styles

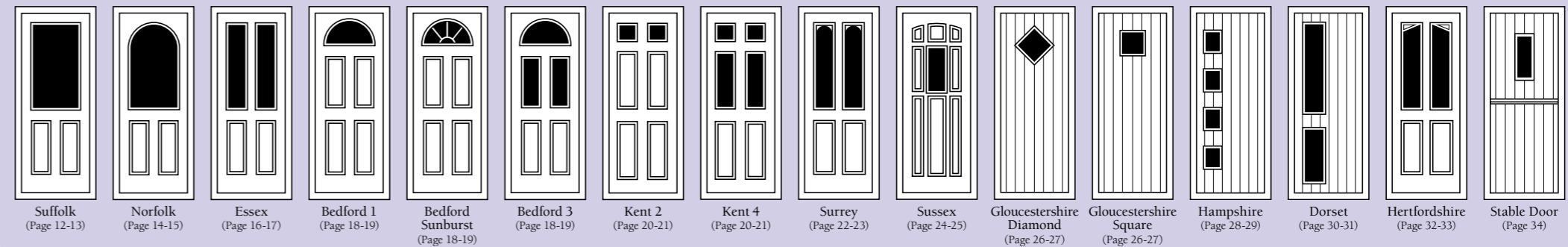

† This sandblast/resin bevel design is not available with a choice of backing glass.

‡ These elegant triple glazed units encapsulate the bevel design within the sealed unit. A choice of backing glass is not available.

* The fusion glass designs are available in red/yellow, green, blue, black/tan and clear colourways to suit your chosen door colour.

** The resin lead and resin bevel designs are available in red, green, blue, black and clear colour options to suit your chosen door.



Personalise Your Door

Your door is as individual as you are. We manufacture every composite door to the customer's exact and bespoke requirements.

Personalise your door from our vast range of options that add a unique finishing touch. Starting with colour, there are seven standard finishes including a Light Wood and Dark Wood. Or choose from our range of 'heritage' shades, such as olive, cream or grey, which are ideal for older or rural homes.

Then decide on your door style from our comprehensive range – glazed or solid, it's up to you. Next, you need to choose what type and style of glazing panel you require. Within our myriad glass designs and styles, there are virtually limitless choices to suit your location and lifestyle.

For back doors, why not combine maximum light with maximum privacy with an integral blind option? Available in the Suffolk door style, an internal venetian blind is incorporated within the sealed glazed unit. The blind, which never needs cleaning, is opened and closed using an external lever.

Composite doors offer better access than many other alternative materials. We offer a choice of low aluminium thresholds in gold or silver with colour-matched weatherbars, plus a lower one designed for easier wheelchair access.

Finally, select your hardware from our attractive ranges of standard or perfectly-matching door furniture in gold, white, black, chrome, bright bronze and satin chrome.

The Composite Door Furniture Options



Standard handles



Scroll handles



Pad handles



All metal letterplate in gold/chrome



also bright bronze & satin chrome



Knockers available with spyholes

handles letterplates knobs knockers glass design

Five Steps to Your Perfect Door:

step 1 step 2 step 3 step 4 step 5

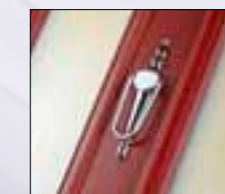
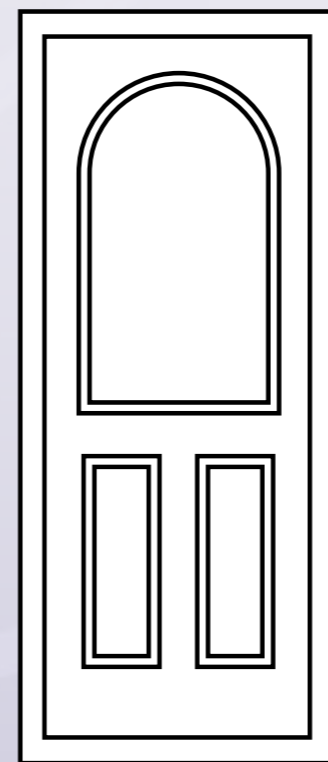

There are a few easy steps to creating your perfect door:

- Step 1** - Decide on your door style. Twin glazed, single or solid, you can choose from our extensive ranges featured in the following pages.
- Step 2** - Choose a colour to suit your property or personal taste, there are seven great woodgrain colour to choose from. (please note a few of our door styles have a reduced colour range)
- Step 3** - Choose a frame colour to suit your door, there are four options available - standard white, black, golden oak or rosewood. (please note golden oak/rosewood are available with the same internal face finish, black frames have a white finish only)
- Step 4** - Select your glass. So many designs to select from, just refer to the pages relating to your door style for details.
- Step 5** - Finally no door is complete without the door furniture, we have a wide range of knockers, letterplates, handles and accessories to enhance your chosen door.

your door



Your very own composite door.

† This sandblast/resin bevel design is not available with a choice of backing glass.

‡ These elegant triple glazed units encapsulate the bevel design within the sealed unit. A choice of backing glass is not available.

* The fusion glass designs are available in red/yellow, green, blue, black/tan and clear colourways to suit your chosen door colour.

** The resin lead and resin bevel designs are available in red, green, blue, black and clear colour options to suit your chosen door.

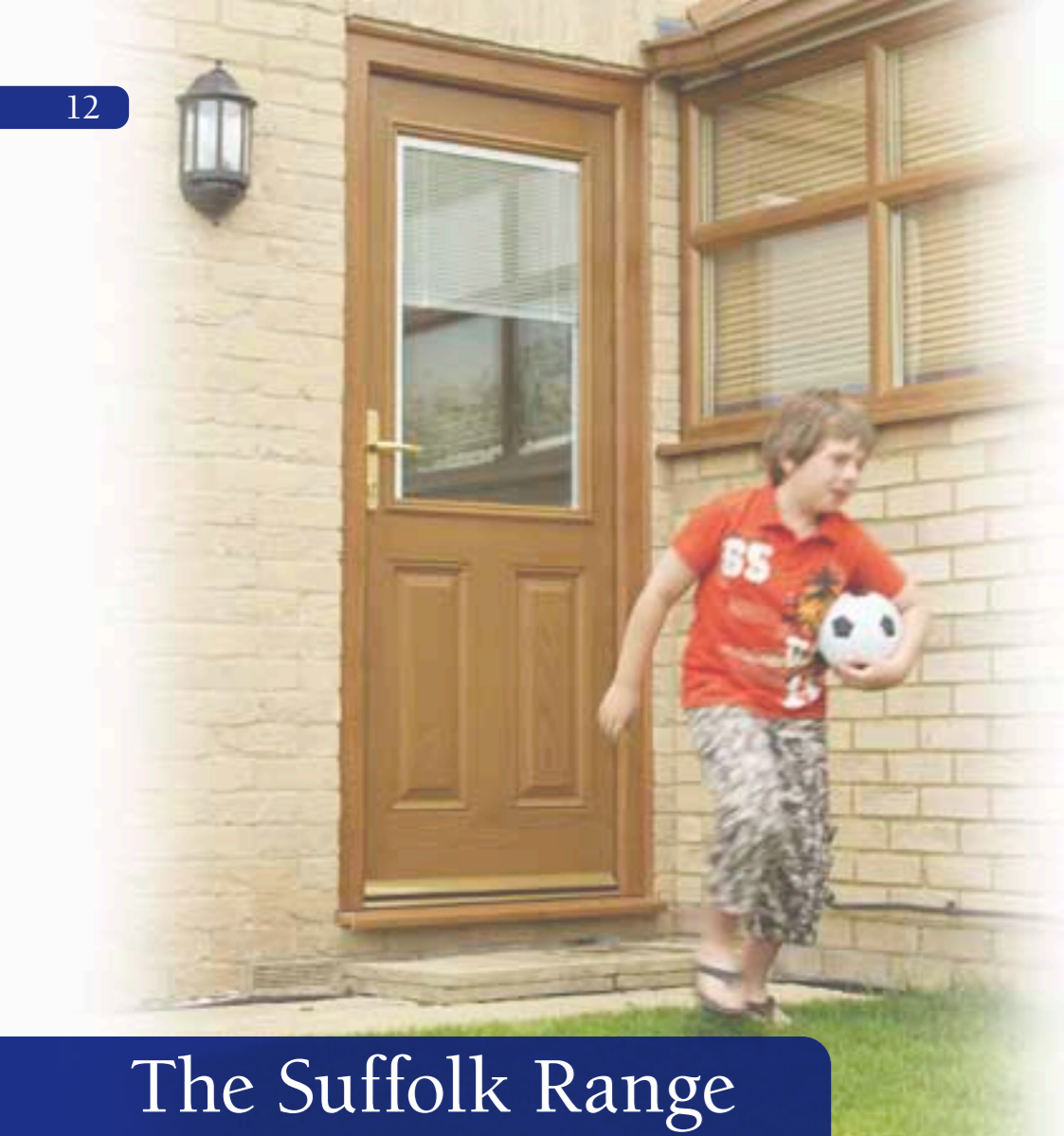

The Suffolk Range

One of our most popular designs, the Suffolk has a single large glass panel allows maximum light into your home. Ideal for darker hallways, it also looks great as a back door. Choose from clear, obscured or patterned glazing from a wide range of aesthetic designs to suit all tastes and situations.



Suffolk Resin Lead Red**



Suffolk Royale ‡

The Suffolk Glazing Options:



Obscure



Diamond Lead



Rectangle Lead



Resin Bevel †**



Resin Bevel †** Coloured



Sandblasted House Number

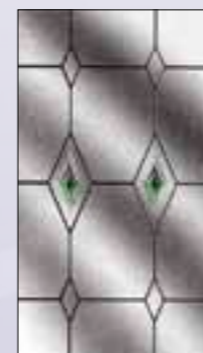

Fusion Style 1 Green*



Fusion Style 2 Red/Yellow*



Fusion Art Green*

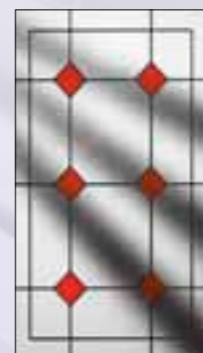

Resin Lead Red**



Brilliance †



Royale ‡



Simplicity ‡



Venetian Blind †



Resin Bevelled †**



Brilliance Design †



Simplicity ‡



Fusion Style 1*

The Suffolk Door Colour Options:

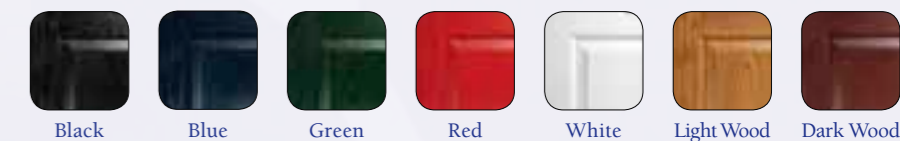

† This sandblast/resin bevel design is not available with a choice of backing glass.
‡ These elegant triple glazed units encapsulate the bevel design within the sealed unit. A choice of backing glass is not available.

* The fusion glass designs are available in red/yellow, green, blue, black/tan and clear colourways to suit your chosen door colour.
** The resin lead and resin bevel designs are available in red, green, blue, black and clear colour options to suit your chosen door.

Please note that all images are provided as a guide only. Due to the nature of the various materials used in the manufacturing process, there may be slight variations in colour between the door outerframes and the door leaves. Handles, letterplates and door furniture may vary. As part of our commitment to continuous improvement, we reserve the right to modify/change the specification without prior notice.



The Norfolk Range

Similar to the Suffolk design, the Norfolk door makes an elegant statement with its arched glazed panel. This still allows plenty of light in through the glass, while lending a 'softer' appearance to the door.



Norfolk 1 Clear Resin Bevel †



Norfolk 1 Green Resin Bevel †**

The Norfolk Glazing Options:



Obscure



Diamond Lead



Rectangle Lead



Brilliance ‡



Resin Bevel †**



Green Resin †** Bevel



Sandblasted House Number

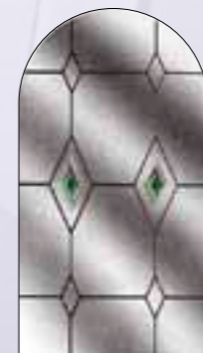

Fusion Style 1 Green*



Fusion Style 2 Black/Tan*



Fusion Art Red/Yellow*



Simplicity ‡



Royale ‡

The Norfolk Door Colour Options:

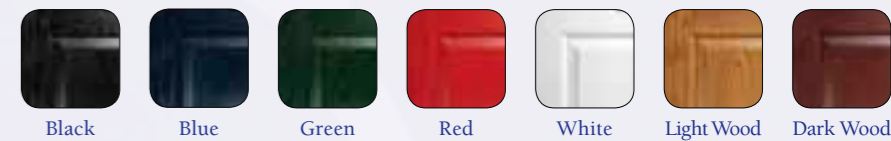

Sandblast House Number



Brilliance †

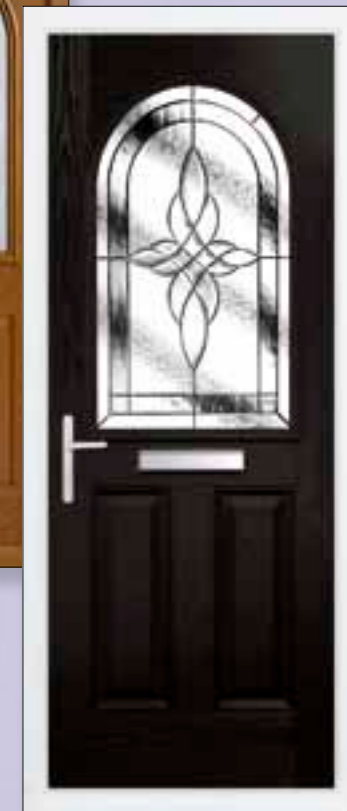

Royale ‡

† This sandblast/resin bevel design is not available with a choice of backing glass.
‡ These elegant triple glazed units encapsulate the bevel design within the sealed unit. A choice of backing glass is not available.

* The fusion glass designs are available in red/yellow, green, blue, black/tan and clear colourways to suit your chosen door colour.
** The resin lead and resin bevel designs are available in red, green, blue, black and clear colour options to suit your chosen door.

Please note that all images are provided as a guide only. Due to the nature of the various materials used in the manufacturing process, there may be slight variations in colour between the door outerframes and the door leaves. Handles, letterplates and door furniture may vary. As part of our commitment to continuous improvement, we reserve the right to modify/change the specification without prior notice.

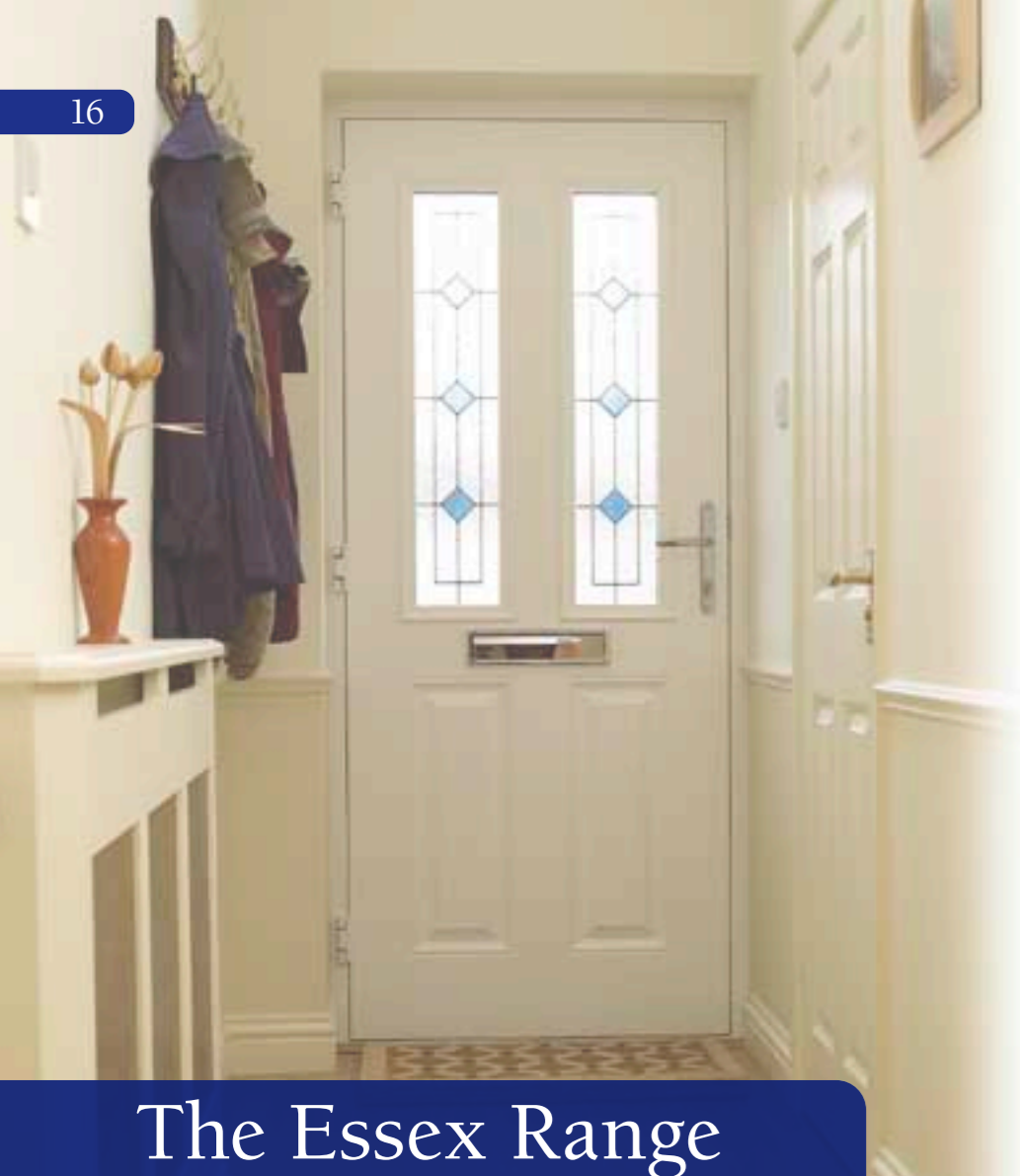

The Essex Range

Suitable for both traditional and modern tastes, the Essex is our top selling design. Its twin glazed panels accept a variety of glass options to your liking. This versatile door style echoes Georgian and Edwardian architectural styles, making it the perfect choice for older properties.



Essex 2 - Jewel ‡ (LowE argon filled triple glazed glass units)



Fusion Tiles Style 1*



Colour Resin Bevel †**



Majestic ‡
(LowE argon filled triple glazed glass units)



Resin Lead Red**

The Essex Glazing Options:

Obscure	Diamond Lead	Brilliance †	Resin Bevel †**	Coloured †** Resin Bevel	Resin Lead † Fleur-de-lys	Fusion Art Blue *
Sandblasted Style 2	Sandblasted Style 3	Sandblasted Style 4	Fusion Style 1 Black/Tan *	Fusion Style 2 Red/Yellow *	Jewel ‡ (LowE argon filled unit)	Majestic ‡ (LowE argon filled unit)
Resin Lead** Red	Black Bevel †** Style 1	Blue Bevel** Style 2	Simplicity ‡	Royale ‡		



Fusion Art Black*



Sandblast Style 1

The Essex Door Colour Options:

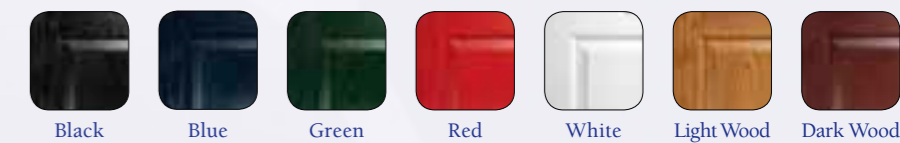

† This sandblast/resin bevel design is not available with a choice of backing glass.
‡ These elegant triple glazed units encapsulate the bevel design within the sealed unit. A choice of backing glass is not available.

* The fusion glass designs are available in red/yellow, green, blue, black/tan and clear colourways to suit your chosen door colour.
** The resin lead and resin bevel designs are available in red, green, blue, black and clear colour options to suit your chosen door.

Please note that all images are provided as a guide only. Due to the nature of the various materials used in the manufacturing process, there may be slight variations in colour between the door outerframes and the door leaves. Handles, letterplates and door furniture may vary. As part of our commitment to continuous improvement, we reserve the right to modify/change the specification without prior notice.



The Bedford Range

Mix and match with the Bedford's flexible glazing options. Choose from one or three glass panels according to your needs and preferences. For privacy with some light, the semi-circular single top glazed panel is ideal for a busy location. Or add two more to brighten your home.











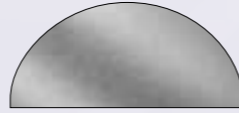
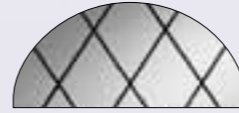

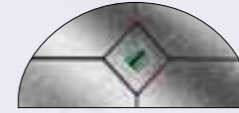



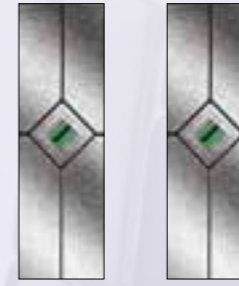





Bedford Majestic ‡
(LowE argon filled triple glazed glass units)



Bedford Jewel ‡ (LowE argon filled triple glazed glass units)

The Bedford Glazing Options:

 Obscure	 Diamond Lead	 Sandblasted House Number	
 Resin Bevel †**	 Coloured Resin †** Bevel	 Red Solar	
 Fusion Style 1 Green*	 Fusion Style 2 Black/Tan*	 Fusion Style 2 with House Number*	
 Fusion Art Green*	 Simplicity ‡	 Royale ‡	
 Sunburst (Available in all colours)	 Brilliance †	 Brass Art Clarity ‡	
 Jewel ‡ (LowE argon filled unit)	 Majestic ‡ (LowE argon filled unit)		



Bedford Sandblasted House Number



Bedford 3 Brass Art Clarity ‡

The Bedford Door Colour Options:

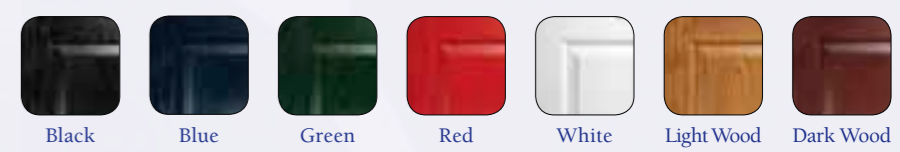

† This sandblast/resin bevel design is not available with a choice of backing glass.
‡ These elegant triple glazed units encapsulate the bevel design within the sealed unit. A choice of backing glass is not available.

* The fusion glass designs are available in red/yellow, green, blue, black/tan and clear colourways to suit your chosen door colour.
** The resin lead and resin bevel designs are available in red, green, blue, black and clear colour options to suit your chosen door.

Please note that all images are provided as a guide only. Due to the nature of the various materials used in the manufacturing process, there may be slight variations in colour between the door outerframes and the door leaves. Handles, letterplates and door furniture may vary. As part of our commitment to continuous improvement, we reserve the right to modify/change the specification without prior notice.



Kent 4 - Light Wood with Clear Bevel**



The Kent Range

The Kent range offers three classic styles to personalise your door. For total privacy on a busy street, choose a solid version with no glass. Two or four glass panels bring more light, with a choice of attractive traditional or contemporary glass designs.

The Kent Glazing Options:

 Obscure	 Obscure	 Diamond Lead	 Diamond Lead	 Sandblast Rose	 Sandblast Rose	 Red Solar	 Red Solar
 Fusion Style 1 Green*	 Fusion Style 1 Green*	 Fusion Style 1 Black/Tan*	 Fusion Style 1 Black/Tan*	 Fusion Style 1 Red/Yellow*	 Fusion Style 1 Red/Yellow*	 Simplicity †	 Simplicity †
 Fusion Style 1 Green*	 Fusion Style 1 Green*	 Fusion Style 1 Black/Tan*	 Fusion Style 1 Black/Tan*	 Fusion Style 1 Red/Yellow*	 Fusion Style 1 Red/Yellow*	 RoyaLe †	 RoyaLe †
 Obscure	 Obscure	 Diamond Lead	 Diamond Lead	 Fusion Style 1 Green*	 Fusion Style 1 Green*	 Fusion Style 1 Black/Tan*	 Fusion Style 1 Black/Tan*
 Fusion Style 1 Red/Yellow*	 Fusion Style 1 Red/Yellow*	 Coloured Bevel**	 Coloured Bevel**	 Clear Bevel**	 Clear Bevel**	 Simplicity †	 Simplicity †
 Fusion Art Red/Yellow*	 Fusion Art Red/Yellow*	 Coloured Bevel**	 Coloured Bevel**	 Clear Bevel**	 Clear Bevel**	 RoyaLe †	 RoyaLe †
 Fusion Art Red/Yellow*	 Fusion Art Red/Yellow*	 Coloured Bevel**	 Coloured Bevel**	 Clear Bevel**	 Clear Bevel**	 Simplicity †	 Simplicity †
 Fusion Art Red/Yellow*	 Fusion Art Red/Yellow*	 Coloured Bevel**	 Coloured Bevel**	 Clear Bevel**	 Clear Bevel**	 RoyaLe †	 RoyaLe †



Kent Solid



Kent 2 Red Solar



Kent 4, Fusion Art Green*

The Kent Door Colour Options:

Black	Blue	Green	Red	White	Light Wood	Dark Wood

† This sandblast/resin bevel design is not available with a choice of backing glass.
‡ These elegant triple glazed units encapsulate the bevel design within the sealed unit. A choice of backing glass is not available.

* The fusion glass designs are available in red/yellow, green, blue, black/tan and clear colourways to suit your chosen door colour.
** The resin lead and resin bevel designs are available in red, green, blue, black and clear colour options to suit your chosen door.

Please note that all images are provided as a guide only. Due to the nature of the various materials used in the manufacturing process, there may be slight variations in colour between the door outerframes and the door leaves. Handles, letterplates and door furniture may vary. As part of our commitment to continuous improvement, we reserve the right to modify/change the specification without prior notice.



The Surrey Range

This new range builds on the popular Essex range with subtle arched tops to the twin glass panels. Square or arched slim vertical panels; the choice is yours.



Surrey Blue Bevel Style 2**



Surrey Fleur de Lys

The Surrey Glazing Options:

Obscure	Diamond Lead	Brilliance †	Resin Bevel †**	Fleur de Lys
Sandblasted Style 1	Sandblasted Style 2	Sandblasted Style 4	Blue Bevel** Style 2	Resin Lead
Fusion Style 1 Black/Tan*	Fusion Style 2 Red/Yellow*	Fusion Art Blue*	Simplicity ‡	Royale ‡



Royale ‡



Fusion Tiles Style 1 Black/Tan*



Sandblast Style 2

The Surrey Door Colour Options:

Black	Blue	Green	Red	White	Light Wood	Dark Wood

† This sandblast/resin bevel design is not available with a choice of backing glass.
‡ These elegant triple glazed units encapsulate the bevel design within the sealed unit. A choice of backing glass is not available.

* The fusion glass designs are available in red/yellow, green, blue, black/tan and clear colourways to suit your chosen door colour.
** The resin lead and resin bevel designs are available in red, green, blue, black and clear colour options to suit your chosen door.

Please note that all images are provided as a guide only. Due to the nature of the various materials used in the manufacturing process, there may be slight variations in colour between the door outerframes and the door leaves. Handles, letterplates and door furniture may vary. As part of our commitment to continuous improvement, we reserve the right to modify/change the specification without prior notice.



The Sussex Range

Perfect for rural homes, the Sussex selection combines style with a degree of privacy. Distinctive moulding lines focus the eye on a single glazed panel that can be customised with our unique handcrafted glass patterns.



Sussex Red Bevel**

The Sussex Glazing Options:



Obscure



Diamond Lead



Red Bevel**



Fusion Style1 Black/Tan*



Fusion Style1 Red/Yellow*



Fleur de Lys



Simplicity ‡



Royale ‡



Brass Art Clarity ‡



Simplicity ‡



Royale ‡



The Sussex in Green with Clear Bevel

The Sussex Door Colour Options:

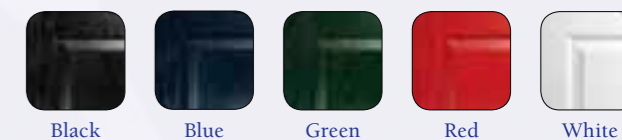

Black

Blue

Green

Red

White

‡ This sandblast/resin bevel design is not available with a choice of backing glass.
 ‡ These elegant triple glazed units encapsulate the bevel design within the sealed unit. A choice of backing glass is not available.

* The fusion glass designs are available in red/yellow, green, blue, black/tan and clear colourways to suit your chosen door colour.
 ** The resin lead and resin bevel designs are available in red, green, blue, black and clear colour options to suit your chosen door.

Please note that all images are provided as a guide only. Due to the nature of the various materials used in the manufacturing process, there may be slight variations in colour between the door outerframes and the door leaves. Handles, letterplates and door furniture may vary. As part of our commitment to continuous improvement, we reserve the right to modify/change the specification without prior notice.



The Gloucestershire Range

This traditional 'cottage-style' door is a favourite with homeowners, suitable for either front or back doors. The Gloucestershire's vertical 'boarded' appearance replicates the rustic 'tongue and groove' timber construction, which makes them ideal for restoration or replacement projects. Square or diamond-shaped glazed panels, with Fusion or bevelled glass options, can be added for additional light.



Bevelled Diamond Green**

The Gloucestershire Glazing Options:



Obscure



Diamond Lead

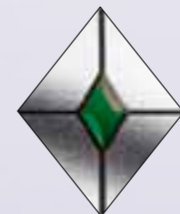

Bevelled**
Diamond Green



Bevelled**
Diamond Red

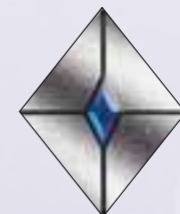

Bevelled**
Diamond Blue



Fusion Style1
Black/Tan*



Fusion Style1
Green*



Fusion Style1
Red/Yellow*



Fusion Tiles Style 1 Black/Tan*



Diamond Bevel Blue**



Square Obscure

The Gloucestershire Door Colour Options:

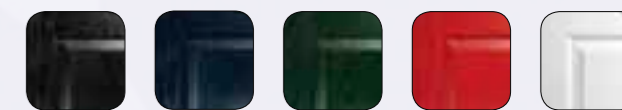

Black Blue Green Red White

† This sandblast/resin bevel design is not available with a choice of backing glass.
‡ These elegant triple glazed units encapsulate the bevel design within the sealed unit. A choice of backing glass is not available.

* The fusion glass designs are available in red/yellow, green, blue, black/tan and clear colourways to suit your chosen door colour.
** The resin lead and resin bevel designs are available in red, green, blue, black and clear colour options to suit your chosen door.

Please note that all images are provided as a guide only. Due to the nature of the various materials used in the manufacturing process, there may be slight variations in colour between the door outerframes and the door leaves. Handles, letterplates and door furniture may vary. As part of our commitment to continuous improvement, we reserve the right to modify/change the specification without prior notice.



Hampshire Bevelled Clear**

The Hampshire Range

European flair combines with British solidarity in the Hampshire range. Four offset glazed panels accept leaded, sandblasted, bevel or 'funky' Fusion designs for an overall creative effect. It's a modern look for a 21st century composite door. It's the perfect for that Docklands apartment or new townhouse.



Hampshire Fusion Tiles Style 1 Black/Tan*

The Hampshire Glazing Options:



Hampshire Fusion Tiles Red/Yellow*

Hampshire Fusion Tiles Black/Tan*

Hampshire Blue Bevel Style 2**

The Hampshire Door Colour Options:

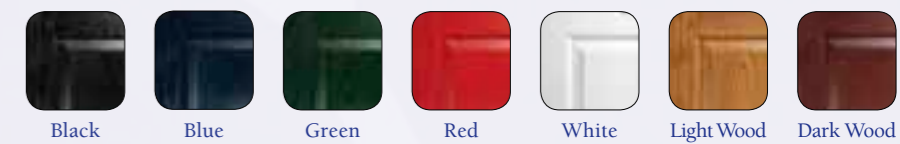

† This sandblast/resin bevel design is not available with a choice of backing glass.
‡ These elegant triple glazed units encapsulate the bevel design within the sealed unit. A choice of backing glass is not available.

* The fusion glass designs are available in red/yellow, green, blue, black/tan and clear colourways to suit your chosen door colour.
** The resin lead and resin bevel designs are available in red, green, blue, black and clear colour options to suit your chosen door.

Please note that all images are provided as a guide only. Due to the nature of the various materials used in the manufacturing process, there may be slight variations in colour between the door outerframes and the door leaves. Handles, letterplates and door furniture may vary. As part of our commitment to continuous improvement, we reserve the right to modify/change the specification without prior notice.



The Dorset Range

Fresh, clean and thoroughly contemporary, the Dorset expands our European theme. Two offset glazed panels illuminate the interior, while affording a degree of privacy. Obscure, leaded, bevelled or Fusion designs all enhance this beautiful door.



Dorset Blue Bevel Style 2**

The Dorset Glazing Options:



Obscure



Diamond Lead



Simplicity †



Fusion Tile Black/Tan*



Fusion Tile Green*



Fusion Tile Red/Yellow*



Fusion Art Green*



Clear Bevel Style 2**



Blue Bevel Style 2**

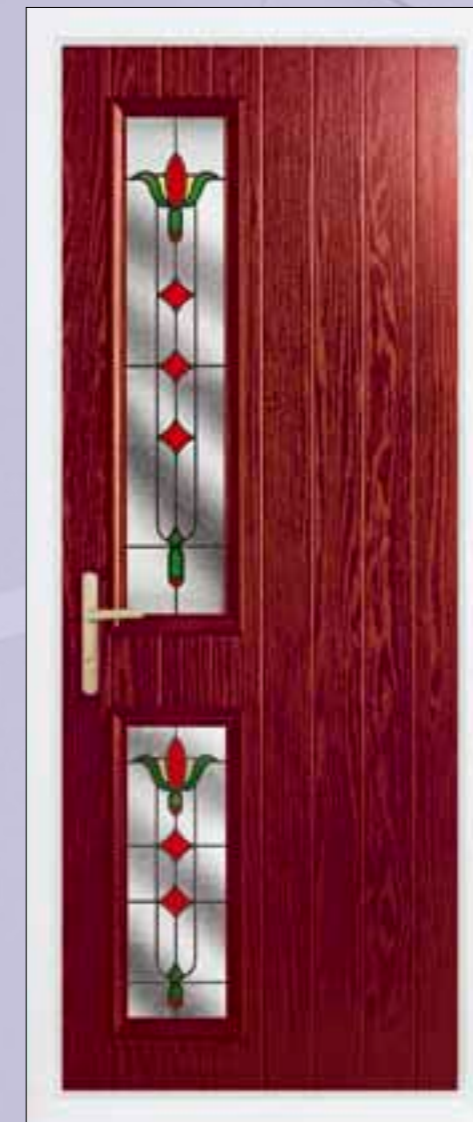

Dorset Fleur de Lys



Clear Bevel Style 2**

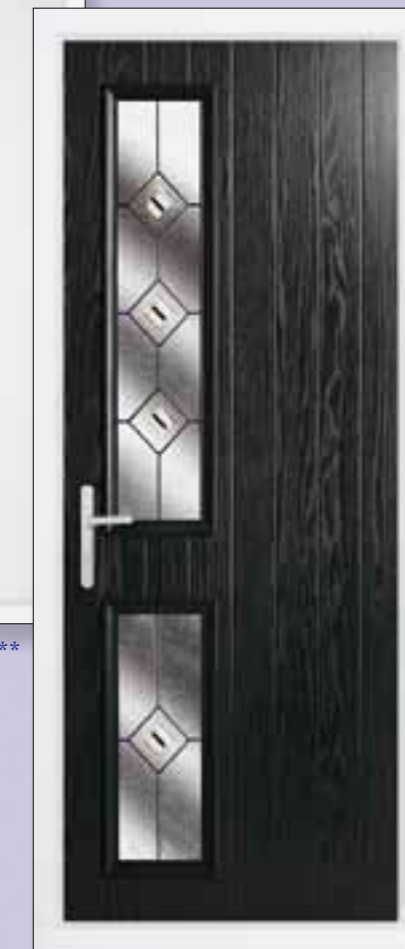

Fusion Tiles Style 2 Black/Tan*

The Dorset Door Colour Options:

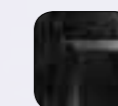

Black

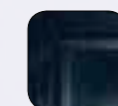

Blue

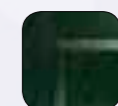

Green



Red



White

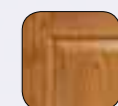

Light Wood

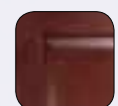

Dark Wood

† This sandblast/resin bevel design is not available with a choice of backing glass.
‡ These elegant triple glazed units encapsulate the bevel design within the sealed unit. A choice of backing glass is not available.

* The fusion glass designs are available in red/yellow, green, blue, black/tan and clear colourways to suit your chosen door colour.
** The resin lead and resin bevel designs are available in red, green, blue, black and clear colour options to suit your chosen door.

Please note that all images are provided as a guide only. Due to the nature of the various materials used in the manufacturing process, there may be slight variations in colour between the door outerframes and the door leaves. Handles, letterplates and door furniture may vary. As part of our commitment to continuous improvement, we reserve the right to modify/change the specification without prior notice.



Hertfordshire Jewel ‡
(LowE argon filled triple glazed units)



Hertfordshire Majestic ‡ (LowE argon filled triple glazed units)



The Hertfordshire

Slanted glazed tops to the Hertfordshire's glazed panels give these doors a distinctive appearance. The 'eyebrow' shapes create a strong visual focal point – complemented with a wide range of exciting glazing options.

The Hertfordshire Glazing Options:

Obscure	Diamond Lead	Resin Bevel †**	Coloured †** Resin Bevel	Blue Bevel** Style 2	Majestic ‡ (LowE argon filled unit)
Sandblasted Style 1	Sandblasted Style 2	Sandblasted Style 3	Sandblasted Style 4	Fusion Art Blue*	Jewel ‡ (LowE argon filled unit)
Fusion Style 1 Black/Tan*	Fusion Style 2 Red/Yellow*	Red Bevel** Style 1	Black Bevel** Style 1	Royale ‡	



Sandblasted Style 4



Hertfordshire Fusion Art Blue*

The Hertfordshire Door Colour Options:

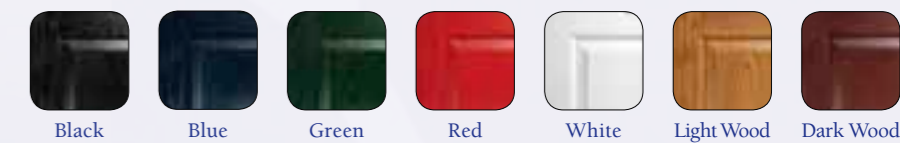

† This sandblast/resin bevel design is not available with a choice of backing glass.
‡ These elegant triple glazed units encapsulate the bevel design within the sealed unit. A choice of backing glass is not available.

* The fusion glass designs are available in red/yellow, green, blue, black/tan and clear colourways to suit your chosen door colour.
** The resin lead and resin bevel designs are available in red, green, blue, black and clear colour options to suit your chosen door.

Please note that all images are provided as a guide only. Due to the nature of the various materials used in the manufacturing process, there may be slight variations in colour between the door outerframes and the door leaves. Handles, letterplates and door furniture may vary. As part of our commitment to continuous improvement, we reserve the right to modify/change the specification without prior notice.

Available as a solid door or glazed with a square or diamond light, the Stable Door comes in a range of colours to suit all types of homes. It's also the ideal choice for country living and outdoor lifestyles.



High security locks are used throughout. The split upper and lower door leafs can be locked to frame independently offering maximum security.



The stable door features high security locks that engage into the outer frame and an interlock between the top and bottom leaf.



The Stable Door in Blue with Obscure Glass



Stable Door, Square Glass

The Stable Door

Our Stable Door offers you the best of both worlds – a window and door in one. Opening the top door only keeps children and pets safe and secure, while allowing fresh air into your home. High security locks and an effective weather-seal ensure it performs just as well as a standard single door. The lower half also accepts cat and dog flaps.

Some of the Twin Door Design Options Available:



Norfolk Double Door with Brilliance Glass †



Suffolk Double Door with Obscure Glass



Dorset Double Door with Fusion Glass*



Hampshire Double Door with Bevelled Glass**



Kent Solid Double Door



Kent 4 Double Door with Simplicity Glass ‡

The Twin Door

Where wider access is required, you can double your options – literally – with the Twin Door. Available in six of our most popular styles, the Twin Door combines practicality with cutting-edge style and security. Great for porches, the Twin Door is also suitable for French Door applications to suit all types of homes.



Essex Double Door with Blue Bevel Glass**

The Stable/Twin Door Colour Options:



Please note that all images are provided as a guide only. Due to the nature of the various materials used in the manufacturing process, there may be slight variations in colour between the door outerframes and the door leafs. Handles, letterplates and door furniture may vary. As part of our commitment to continuous improvement, we reserve the right to modify/change the specification without prior notice.

† This sandblast/resin bevel design is not available with a choice of backing glass.

‡ These elegant triple glazed units encapsulate the bevel design within the sealed unit. A choice of backing glass is not available.

* The fusion glass designs are available in red/yellow, green, blue, black/tan and clear colourways to suit your chosen door colour.

** The resin lead and resin bevel designs are available in red, green, blue, black and clear colour options to suit your chosen door.

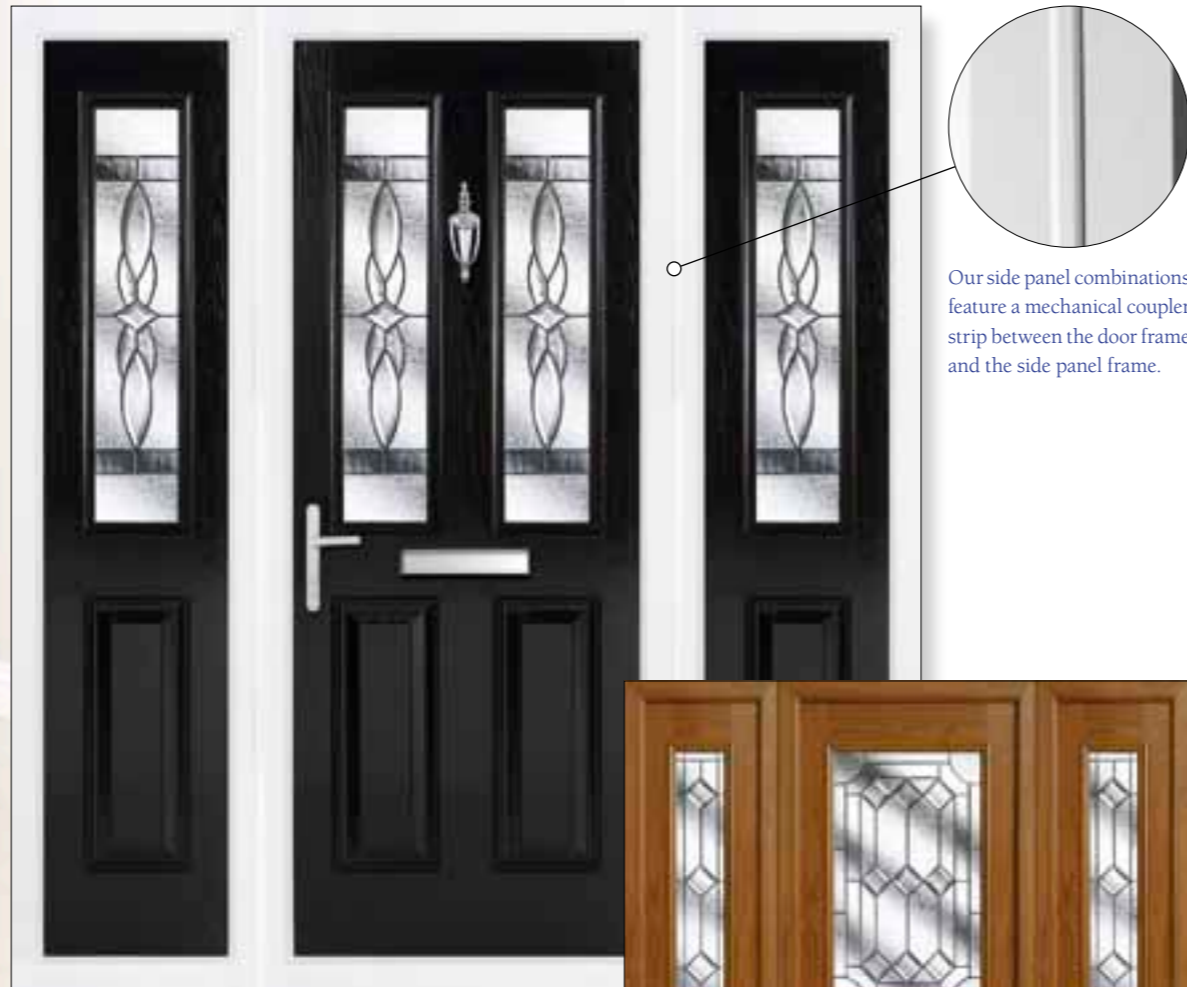

Our side panel combinations feature a mechanical coupler strip between the door frame and the side panel frame.

Essex Twin Side Panel with Royale Glass ‡



Suffolk Twin Panel with Simplicity Glass ‡

Door Combinations

Complement your entrance door with matching side panels. Perfect for wider apertures, there are a number of possible combinations from our Suffolk and Essex ranges. Where space allows, side panels enhance darker interiors by increasing light levels and present a smart and co-ordinated appearance to the outside world.

‡ This sandblast/resin bevel design is not available with a choice of backing glass.
 ‡ These elegant triple glazed units encapsulate the bevel design within the sealed unit. A choice of backing glass is not available.

* The fusion glass designs are available in red/yellow, green, blue, black/tan and clear colourways to suit your chosen door colour.
 ** The resin lead and resin bevel designs are available in red, green, blue, black and clear colour options to suit your chosen door.



Essex Door and a Half with Simplicity Glass ‡



Inside View of our Door and a Half

The Door and a Half

Our 'Door and a Half' is literally just that – a composite door plus matching hinged side panel. This can be opened up to allow wider access, for example when moving large items of furniture.

Please note that all images are provided as a guide only. Due to the nature of the various materials used in the manufacturing process, there may be slight variations in colour between the door outerframes and the door leaves. Handles, letterplates and door furniture may vary. As part of our commitment to continuous improvement, we reserve the right to modify/change the specification without prior notice.

The Backing Glass Options:



Our Composite door range offers the option of choosing your preferred backing glass. The backing glass sits on the inside face of the double glazed cassettes.
 N.b. This option isn't available for the triple glazed designs.

The Door Colour Options:



Specification

All our doors undergo rigorous testing to meet the latest security standards and regulations. They come with a full ten-year guarantee, giving you peace of mind.



All our locks offer excellent levels of security and peace of mind. We have high security options available, tested to PASS 23/24 accreditation.



Composite Door - Technical Data

1.0 Guidance

1.1 Care Of The Product

When using cleaning and lubricating products always follow the manufacturer's instructions; take care not to use an excessive quantity. For cleaning products, test a small area of the product in an obscure location first.

Note: Do not use solvent-based or abrasive cleaning products or products containing bleaching agents.

2.0 Surveying Points

2.1 Existing Load-bearing Doorsets

Check to ensure that there is a lintel or other suitable load-transferring structure above the door set. Plastics doorsets are not designed to carry dead loads.

2.2 Outward Opening Doorsets

Check the correct mode of opening (inward or outward). On outward opening doorsets a restrictor, such as an overhead restrictor, may be required as the door leaf may be subject to sudden movement by wind gusting.

2.3 Cill & Threshold

The requirement for a cill of the appropriate size and the threshold type to be used shall be checked, with attention paid to the internal floor level and the need for the door to swing clear of internal floor-coverings.

3.0 Measurement

3.1 Flat Doors

3.1.1 Width measurement

The width of the aperture shall be measured at three points - the top, middle, and bottom of the opening. The smallest of these is used to determine the aperture width (See Fig 1. Flat measurement).

3.1.2 Height measurement

The height of the aperture shall be measured at three points - the left, middle, and right of the opening. The smallest of these is used to determine the aperture height (See Fig 1. Flat measurement).

3.1.3 Diagonal measurement

The squareness of the aperture shall be checked by measuring the diagonals of the aperture. If the diagonals are more than 10mm different, then the client shall be informed, and a solution agreed (See Fig 1. Flat measurement).

3.1.4 Front to Back Dimension

Check that the installation of the new frame will not cause problems with the DPC or cavity closing.

3.2 Walls & Apertures

The aperture shall be checked to ensure that it is plumb and level.

3.3 Reveal Sizes

The difference between the internal and external reveal sizes shall be checked to ensure that the opening of the door or any door fitting will not be impeded by plaster, render or tiles etc.

4.0 Installation - Replacement

4.1 Pre-installation Checks

Prior to commencing any installation work, the sizes, type, and condition of all doorsets should be checked against both the survey sizes as well as the actual aperture sizes. The door set specification, including hardware, glazing and door style, should be checked against the order acknowledgement provided by the door set supplier. Before discarding any packaging for ancillary components which may be supplied loose, particularly lever handles. Check that all ancillary components required are accounted for.

Note: composite doorsets must be stored in a dry location prior to installation. Prolonged exposure to moisture may invalidate any applicable product guarantee.

4.2 Positioning Of Doorsets

The positioning of the new frame in the aperture is fundamental to the success of the installation. In general the replacement door set shall –

- Bridge the cavity
- Cover the DPC
- Be set back as far as possible in the aperture to minimise exposure to the elements

4.3.1 Fixing distances

Generally, all four sides of the frame shall be secured using the following guidelines to determine the fixing spacings –

- Corner fixings should be a minimum of 150mm and a maximum of 250mm in from the external corner
- No mullion or transom fixings should be closer than 150mm, or further than 250mm from the centre line of a mullion or transom
- Intermediate fixings should be at centres no greater than 600mm
- There must be a minimum of 2 fixings on each jamb – (Fig.2 illustrates fixing positions)

Note: If it is impossible to find a suitable fixing position, then the nearest possible fixing should be used.

4.3.2 Use of installation packers

Appropriately sized installation packers shall be used adjacent to fixing positions to prevent outer frame distortion during installation. Installation packers should be incompressible, resistant to rot or corrosion, and span the full width of the outer frame profile. For fire doorsets they should be of a hard, stable material. The fixings should be tightened so that the frame is held securely against the packers. Take care not to over-tighten the screws and distort the frame. Apply a small amount of silicone mastic to the shanks and heads of fixings that pass through the outer frame to ensure that no water penetrates into the frame.

Note: packers shall be used adjacent to hinge/locking points.

5.0 Perimeter Sealing

5.1 Drainage

When sealing perimeter joints take care to ensure any drainage channels are not blocked or obstructed.

EUROCELL Frame - Comp Door Sizes (Min/Max)

Designs	Colours Available	Max Width	Max Ht Std Threshd	Max Height Low Alu	Max Height Low PVC	Min Width	Min Height Low Alu	Min Height Low PVC
Suffolk 1	All	1020	2130	2085	2108	850	1995	2015
Norfolk 1	All	1020	2130	2085	2108	850	1995	2015
Essex 2	All	1020	2130	2085	2108	850	1995	2015
Bedford 1	All	1020	2130	2085	2108	850	1995	2015
Kent 1	All	1020	2130	2085	2108	850	1995	2015
Kent 2	All	1020	2130	2085	2108	850	1995	2015
Surrey 2	All	1020	2130	2085	2108	850	1995	2015
Sussex 1	Green, Blue, Red, White	1020	2130	2085	2108	850	1995	2015
Gloucester	Green, Blue, Red, White	1020	2130	2085	2108	850	1995	2015

DURAFLEX Frame - Comp Door Sizes (Min/Max)

Designs	Colours Available	Max Width	Max Ht Std Threshd	Max Height Low Alu	Max Height Low PVC	Min Width	Min Height Low Alu	Min Height Low PVC
Suffolk 1	All	1010	2115	2080	2100	835	1995	2000
Norfolk 1	All	1010	2115	2080	2100	835	1995	2000
Essex 2	All	1010	2115	2080	2100	835	1995	2000
Bedford 1	All	1010	2115	2080	2100	835	1995	2000
Kent 1	All	1010	2115	2080	2100	835	1995	2000
Kent 2	All	1010	2115	2080	2100	835	1995	2000
Surrey 2	All	1010	2115	2080	2100	835	1995	2000
Sussex 1	Green, Blue, Red, White	1010	2115	2080	2100	835	1995	2000
Gloucester	Green, Blue, Red, White	1010	2115	2080	2100	835	1995	2000

Please note: All heights exclude 30mm cill; Low PVC threshold available in WHITE only; Arched doors not available; Colour match between the outerframe in Rosewood and Light Oak and door slabs in Dark Wood and Light Wood is not exact due to differences in the material.

Mid Rail Heights

To be used for lining midrails up when with a door combination with side panel

Door Style	Slab Type (Ref.)	Measurement
Suffolk	105	1190mm
Norfolk	106	1180mm
Essex	103 203	1200mm
Bedford	101	1190mm
Kent 2	101	1180mm
Kent 4	102 116	1190mm
Surrey	110	1200mm
Gloucestershire	n/a	n/a

Please note: All measurements are taken from the top of the outerframe; Measurements can change if a small door is being manufactured; A small door may be cut from the top and bottom of the slab so please check with the office before ordering.

